

FEATURES:

- Comply with RoHS standard, UL1950, IEC950 safety procedures
- Wide voltage input range, broadband noise filtering; Low ripple output
- Typical efficiency 82%
- High isolation voltage, short circuit, overload, overheat protection self-recovery
- Miniaturized design
- Fast dynamic response
- Size: 81.5*68*17mm
- Weight: 160g
- Widely used in military, communications, industrial control, transportation, electric power, new energy and scientific research and experiment and other fields



Selection Guide

Part No.	INPUT		OUTPUT				CapacitiveLoad(μF)
	Normal (VAC)	Range (VAC)	Voltage (V1dc)	current (A)	Voltage (V2dc)	current (A)	
LD150E-12S12M	12	9-18	12	12.5			
LD150E-12S15M			15	10			
LD150E-12S19M			19	7.89			
LD150E-12S24M			24	6.25			
LD150E-12S28M			28	5.36			
LD150E-12S48M			48	3.13			
LD150E-24S12M	24	18-36	12	12.5			
LD150E-24S15M			15	10			
LD150E-24S19M			19	7.89			
LD150E-24S24M			24	6.25			
LD150E-24S28M			28	5.36			
LD150E-24S48M			48	3.13			
LD150E-48S12M	48	36-72	12	12.5			
LD150E-48S15M			15	10			
LD150E-48S19M			19	7.89			
LD150E-48S24M			24	6.25			
LD150E-48S28M			28	5.36			
LD150E-48S48M			48	3.13			
LD150E-110S12M	110	72-144	12	12.5			
LD150E-110S15M			15	10			
LD150E-110S19M			19	7.89			
LD150E-110S24M			24	6.25			
LD150E-110S28M			28	5.36			
LD150E-110S48M			48	3.13			
LD150E-18S12M	18	9-36	12	12.5			
LD150E-18S15M			15	10			

LD150E-18S19M			19	7.89		
LD150E-18S24M			24	6.25		
LD150E-18S28M			28	5.36		
LD150E-18S48M			48	3.13		

customized accepted,pls contact sales for details

Input Specifications

Input Voltage Range	Input Voltage Range (Vdc)	Nom(Vdc)	Max (Vdc)
	9-18	12	18
	9-36	18	36
	18-36	24	36
	36-72	48	72
	72-144	110	144

Output Specifications

Item	Min	Typ	Max	Test Conditions
Voltage Accuracy		±1%		
Voltage Adjust Rate		±0.2%		
Load Regulation		±0.5%		
Auxiliary Voltage Accuracy		±3%		
Ripple&Noisy		±1%		
Temperature Regulation		±0.02%/°C		
Over Current Protect	120%		150%	
Short Circuit Protect	Burp type, self-recovery			
Dynamic Response	400μS		25% load	

General Specifications

Isolation Resistor	200MΩ	Input-Output
Isolation Voltage	1000VDC	Input-Output
	500VDC	Input-Case
	500VDC	Output-Case
Switching Frequency	300KHz	Mil HDBK 217F Tc=25°C
MTBF	200000Hrs	
Case Temperature	-40~+100°C	
Storage Temperature	-55~+125°C	
Relative Humidity	5%-90%	
Pin Solder Temperature	250°C	Soldering spot is 1.5mm away from case for 10 seconds
Hand Soldering Time	5s	Iron Temperature 425 °C
Temperature Coefficient	±0.02%/°C	
Shock	5G	10~55Hz
Cooling	Free Air	
Weight	160g (Typ)	

**Unless specified, otherwise all other parameters are tested under the following conditions: nominal input voltage, pure resistive load, 25°C room temperature environment.

Dimensions and Recommended Layout

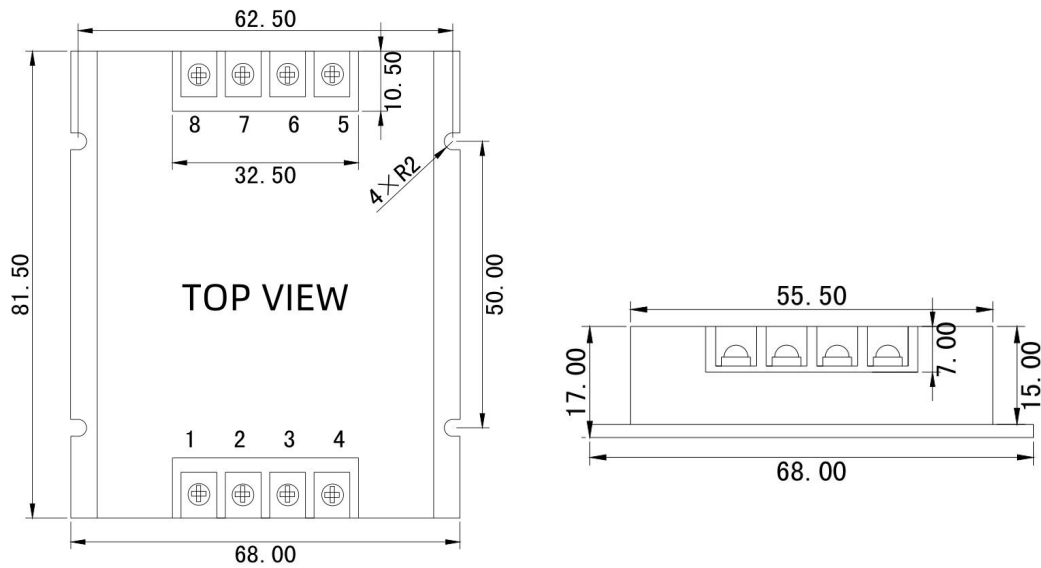

Unit:mm

Recommended Circuit



Remark:

Adding input capacitor C_{IN} helps to improve electromagnetic compatibility. Electrolytic capacitor 47 uf-100uf C_{IN} is recommended. If the module is connected to a digital circuit, add c_{out} , c_{out1} , c_{out2}

Noted

1. Input current: Ensure that the output current of the power supply meets the instantaneous starting current of the power module (that is, twice the average input current of the power module).
2. Output load requirements: Avoid no-load use. When the actual power consumption of the load is less than 10% of the rated output power of the module or no load occurs, connect an external resistance to the output end (the sum of the external resistance and the load power is greater than or equal to 10% of the rated load) or select a module with a smaller rated power.
3. The external capacitance of the output end should not be too large; otherwise, the module may be overcurrent or poorly started. For details, see the external capacitance recommendation table.
4. External LC filter circuit can be connected for occasions with high ripple noise requirements.