

FEATURES:

- 75VAC/25Hz sine wave output
- Negative logic control (-0.3 ~ 1.5VDC or suspended open)
- 5VDC or suspended open,maximum 5% harmonic distortion degree
- Output short-circuit protection,self-recovery
- 1.5KV isolation
- Working temperature -40~+70°C
- Mainly used in telephone exchange,fixed network local loop,satellite telephone,small earth station terminal,sonar system,VOIP gateway and other equipment

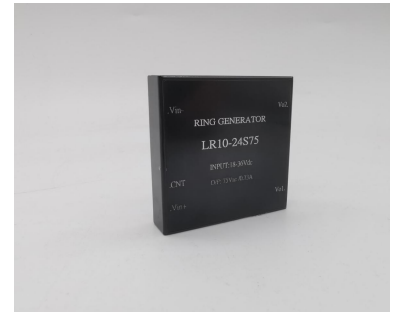

Selection Guide

Part No.	INPUT		OUTPUT				CapacitiveLoad(μF)
	Normalal (Vdc)	Range (Vdc)	Voltage (V1dc)	current (mA)	Voltage (V2dc)	current (mA)	
LR15-24S75	24	18-36	75	200			
LR15-48S75	48	36-72	75	200			

customized accepted ,pls contact sales for details

Input Specifications

Input Voltage	Input Voltage Range (Vdc)	Nom(Vdc)	Max (Vdc)
	18-36	24	36
	36-72	48	72
CTRL	ON	CNT pin left open or connected to+Vin	
	OFF	CNT pin connected to -Vin	
Logic Low			0.8VDC
Start-up Delay Time			2.5S

Output Specifications

Item	Typ	Max	Test Conditions
Voltage Accuracy	±1%	±3%	
Line Regulation		±0.5%	
Load Regulation		±1%	
Total Harmonic Distortin	±2%	±5%	
Short-circuit Protection	Continuous, self-recovery		

General Specifications

Efficiency		80%(typ)
Switching Frequency	25Hz(Typ)	PWM mode
MTBF	1000 K hours	MIL-HDBK-217F@25°C
Pin Solder Temperature	250°C	Wave Solder<10S
Isolation (Input-Output)	1.5KVDC	
Hand Soldering Time	5S	Iron Temperat
Operating Temperature	-40~+70°C	
Storage Temperature	-55~+125°C	
Storage Humidity	10-90%	Non-condensing

Cooling Method	Free air convection	
Case Material	Aluminum alloy	
Weight	60g (Typ)	

**Unless specified, otherwise all other parameters are tested under the following conditions: nominal input voltage, pure resistive load, 25°C room temperature environment.

Dimensions and Recommended Layout

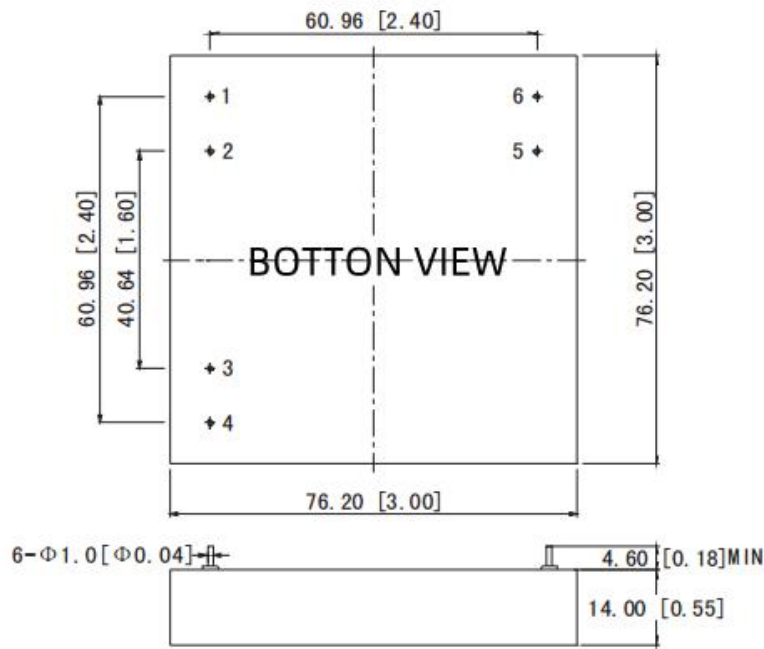

Note:
Unit: mm[inch]
Pin diameter tolerances: $\pm 0.10[\pm 0.004]$
General tolerances: $\pm 0.50[\pm 0.020]$

Pins

Pin	Single		
1	+Vin		
2	-Vin		
3	CASE		
4	CNT		
5	Vo2		
6	Vo1		

Recommended Circuit

With DC Bias Circuit

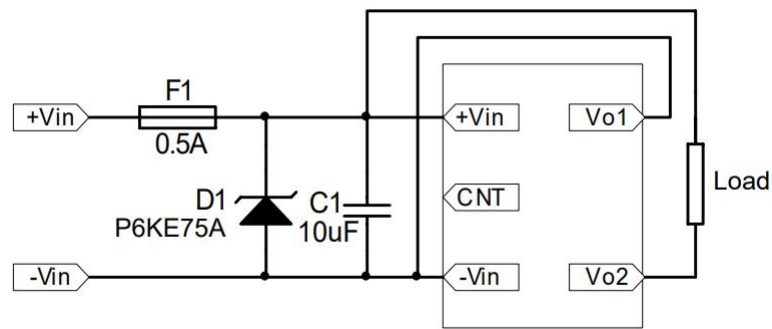

Without DC Bias Circuit

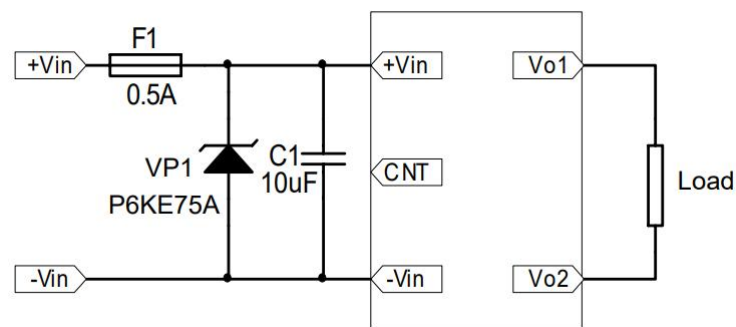
**Noted**

1. Input current: Ensure that the output current of the power supply meets the instantaneous starting current of the power module (that is, twice the average input current of the power module).
2. Output load requirements: Avoid no-load use. When the actual power consumption of the load is less than 10% of the rated output power of the module or no load occurs, connect an external resistance to the output end (the sum of the external resistance and the load power is greater than or equal to 10% of the rated load) or select a module with a smaller rated power.
3. The external capacitance of the output end should not be too large; otherwise, the module may be overcurrent or poorly started. For details, see the external capacitance recommendation table.
4. External LC filter circuit can be connected for occasions with high ripple noise requirements.