

**FEATURES:**

- Wide input range
- Continuous short-circuit protection, self recover
- I/O isolation voltage 2250V
- Working temperature: -40°C~+100°C
- No additional components required
- Stable performance and high reliability (MTBF≥500K hours)
- Industry standard 1/4 brick pin-out



**Selection Guide**

Part No.	INPUT		OUTPUT				CapacitiveLoad(μF)
	Normal (Vdc)	Range (Vdc)	Voltage (V1dc)	current (mA)	Voltage (V2dc)	current (mA)	
LD75G-12S12	12	9-18	12	6.25			
LD75G-12S15			15	5000			
LD75G-12S24			24	3125			
LD75G-12S28			28	2679			
LD75G-12S48			48	1563			
LD75G-18S12	18	9-36	12	6.25			
LD75G-18S15			15	5000			
LD75G-18S24			24	3125			
LD75G-18S28			28	2679			
LD75G-18S48			48	1563			
LD75G-24S3V3	24	18-36	3.3	22727			
LD75G-24S05			5	15000			
LD75G-24S12			12	6.25			
LD75G-24S15			15	5000			
LD75G-24S24			24	3125			
LD75G-24S28			28	2679			
LD75G-24S48			48	1563			
LD75G-36S12	36	18-72	12	6.25			
LD75G-36S15			15	5000			
LD75G-36S24			24	3125			
LD75G-36S28			28	2679			
LD75G-36S48			48	1563			
LD75G-48S05	48	36-72	5	15000			
LD75G-48S12			12	6.25			
LD75G-48S15			15	5000			
LD75G-48S24			24	3125			
LD75G-48S28			28	2679			
LD75G-48S48			48	1563			
LD75G-110S05	110	72-144	5	15000			
LD75G-110S12			12	6.25			

LD75G-110S15			15	5000			
LD75G-110S24			24	3125			
LD75G-110S28			28	2679			
LD75G-110S48			48	1563			
LD75G-300S05	300	200-400	5	15000			
LD75G-300S12			12	6.25			
LD75G-300S15			15	5000			
LD75G-300S24			24	3125			
LD75G-300S28			28	2679			
LD75G-300S48			48	1563			

\*\*customized accepted,pls contact sales for details\*\*

## Input Specifications

Item	Min	Typ	Max	Test Conditions
Reflected Ripple Current	-	30mA	-	
Impulse Voltage(1sec.max.)	0.7VDC	-	90VDC	
Start Voltage	-	-	18VDC	
Input Undervoltage Protection	16VDC	16.5VDC		5V,15V
	15VDC	15.4VDC		Others part number
CTRL	CTRL left open or TTL high level(3.5-12VDC)			Turn on
	CTRL connect -Vin or low level(0-1.2VDC)			Turn off
	-	2mA	10mA	Turn off input current
Hot Plug	Unavailable			

## Output Specifications

Item	Min	Typ	Max	Test Conditions
Voltage Accuracy		±1%	±3%	Full load, input voltage from low voltage to high voltage
Line Regulation		±0.2%	±0.5%	
Load Regulation		±0.5%	±0.75%	5%-100% Load
Transient Recovery Time	-	200μs	500μs	25% load variation
Transient Response Deviation	5V	±3%	±7.5%	25% load variation
	others	±3%	±5%	
Temperature Drift Coefficient	-	-	±0.03%/°C	Full Load
Ripple&Noisy	12V,15V	-	100mVp-p	200mVp-p
	others	-	130mVp-p	250mVp-p
Over Current Protect	110%Vo	125%Vo	160%%Vo	
Over Voltage Protect	110%lo	125%lo	190%lo	
Over Temperature Protect	-	+115°C	+120°C	
Short Circuit Protect	Hiccup Style,Continuous, self-recovery			

## General Specifications

Insulation Resistance	100MΩ	Input-Output,Insulation Voltage 500VDC
Isolation Voltage	2250VDC	Input-Output
	1500VDC	Input-Case

	500VDC	Output-Case
Isolation Capacitance	2200pF	
Switching Frequency	250KHz	PWM
MTBF	500K Hrs	Mil HDBK 217F Tc=25°C
TRIM	95%Vo(Min),110%Vo(Max)	
Sense	105%Vo(Max)	
Case Temperature	-40~+100°C	
Storage Temperature	-55~+125°C	
Relative Humidity	10%-90%	
Pin Solder Temperature	250°C	Soldering spot is 1.5mm away from case for 10 seconds
Hand Soldering Time	10s	Iron Temperature 260 °C
Weight	60g (Typ)	

\*\*Unless specified, otherwise all other parameters are tested under the following conditions: nominal input voltage, pure resistive load, 25°C room temperature environment.

**Dimensions and Recommended Layout**

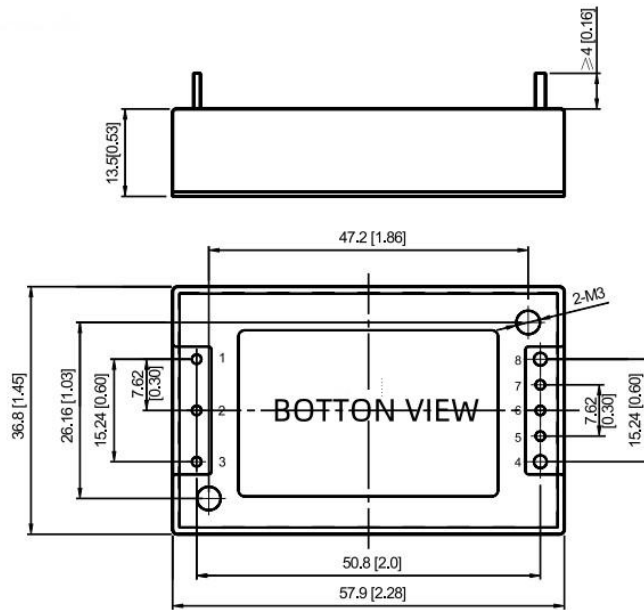

Note:  
Unit: mm[inch]  
Pin diameter tolerances:  $\pm 0.10 [\pm 0.004]$   
General tolerances:  $\pm 0.50 [\pm 0.020]$

**Pins**

Pin-Out	Mark		
1	-Vin		
2	CTRL		
3	+Vin		
4	+Vo		

5	+S		
6	TRIM		
7	-S		
8	-Vo		

**Recommended Circuit**

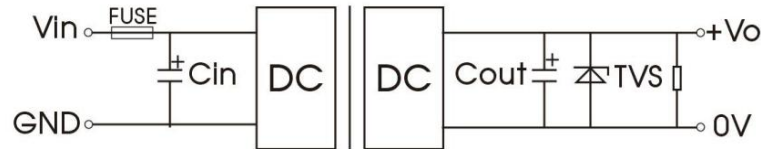

Vout(VDC)	Fuse	Cin	Cout	TVS
5	10A.	220μF	470μF	SMDJ6.0A
12			220μF	SMDJ14A
15				SMDJ17A
24			100μF	SMDJ28A
48				SMDJ54A

**Noted**

1. Input current: Ensure that the output current of the power supply meets the instantaneous starting current of the power module (that is, twice the average input current of the power module).
2. Output load requirements: Avoid no-load use. When the actual power consumption of the load is less than 10% of the rated output power of the module or no load occurs, connect an external resistance to the output end (the sum of the external resistance and the load power is greater than or equal to 10% of the rated load) or select a module with a smaller rated power.
3. The external capacitance of the output end should not be too large; otherwise, the module may be overcurrent or poorly started. For details, see the external capacitance recommendation table.
4. External LC filter circuit can be connected for occasions with high ripple noise requirements.