

FEATURES:

- Fixed voltage input, unregulated dual output, 1W
- Continuous short-circuit protection, self recover
- I/O isolation voltage 3KV
- Working temperature: -40°C~+105°C
- No additional components required
- Stable performance and high reliability (MTBF≥3500K hours)
- Industry standard pin-out
- Flame-retardant case to meet UL94-V0 requirements
- SIP package

Selection Guide

Part No.	INPUT		OUTPUT			Full Load Efficiency (%/Typ)	Capacitive Load(μF)
	Normal (Vdc)	Range (Vdc)	Voltage (Vdc)	Min current (mA)	Max current (mA)		
IE0505S-1W	5	4.75-5.25	±5	±10	±100	54	
IE0509S-1W			±9	±6	±56	63	
IE0512S-1W			±12	±5	±42	63	
IE0515S-1W			±15	±4	±33	65	
IE1205S-1W	12	11.4-12.6	±5	±10	±100	56	
IE1209S-1W			±9	±6	±56	62	
IE1212S-1W			±12	±5	±42	65	
IE1215S-1W			±15	±4	±33	66	
IE2405S-1W	15	14.25-15.75	±5	±10	±100	54	
IE2409S-1W			±9	±6	±56	62	
IE2412S-1W			±12	±5	±42	64	
IE2415S-1W			±15	±4	±33	66	
IE2424S_1W			±24	±3	±20	66	

customized accepted, pls contact sales for details

Input Specifications

Input Filter	Capacitive Filter	
Ctrl	NONE	
	NONE	
Hot Plug	Unavailable	

Output Specifications

Item	Typ	Max	Test Conditions
Voltage Accuracy	±1%	±3%	input voltage range and load
Line Regulation	±0.2%	±0.5%	Input voltage from low to high voltage, full load
Load Regulation	±0.5%	±1%	10% to 100% full load
Ripple&Noise	50mVp-p	150mVp-p	20MHz Bandwidth, full load

General Specifications

Switching Frequency	300KHz(Typ)	100% full load, nominal input voltage
Short-Circuit Protection	Continuous, self-recovery	
Case Temperature Rise	15°C (Typ)	
Temperature Coefficient	0.03%/°C	100% full load
Pin Soldering Resistance Temperature	300°C	Soldering spot is 1.5mm away from case for 10 seconds
Isolation (Input-Output)	3KVDC	Input-output electric strength test for 1 minute with a leakage current
Insulation Resistance (Input-Output)	1000MΩ	Input-output resistance 500Vdc
Operating Temperature	-40~+105°C	
Storage Temperature	-55~+125°C	
Storage Humidity	<95%	Non-condensing
Cooling Method	Free air convection	
Case Material	Black plastic; flame-retardant and heat-resistant (UL94 V-0)	
Weight	2.1g (Typ)	

**Unless specified, otherwise all other parameters are tested under the following conditions: nominal input voltage, pure resistive load, 25°C room temperature environment.

Dimensions and Recommended Layout

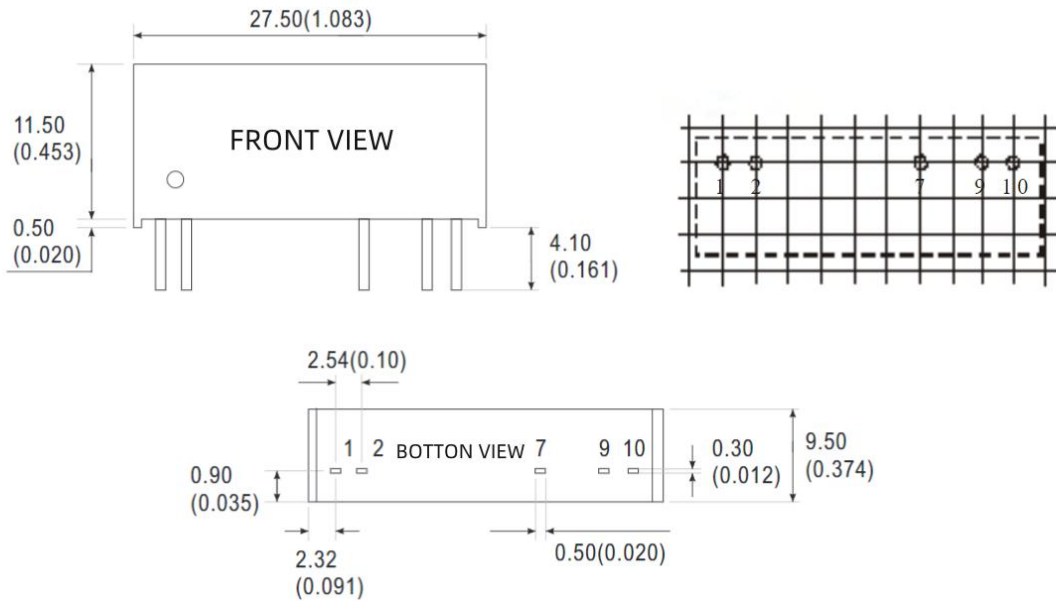

Noted:
Unit:mm(inch)

Pinout

Pin	Mark		
1	Vin		
2	GND		
7	+Vo		
9	-Vo		

10	0V		
----	----	--	--

Recommended Circuit



Single Vout	Cout	Vo	Cout
5VDC	4.7uF	±5VDC	4.7uF
12VDC	2.2uF	±9VDC	2.2uF
24VDC	1uF	±12VDC	1uF
-	-	±15V	0.47uF

Noted

1. Input current: Ensure that the output current of the power supply meets the instantaneous starting current of the power module (that is, twice the average input current of the power module).
2. Output load requirements: Avoid no-load use. When the actual power consumption of the load is less than 10% of the rated output power of the module or no load occurs, connect an external resistance to the output end (the sum of the external resistance and the load power is greater than or equal to 10% of the rated load) or select a module with a smaller rated power.
3. The external capacitance of the output end should not be too large; otherwise, the module may be overcurrent or poorly started. For details, see the external capacitance recommendation table.
4. External LC filter circuit can be connected for occasions with high ripple noise requirements.