

FEATURES:

- Wide input range
- Continuous short-circuit protection, self recover
- I/O isolation voltage 1.6KV
- Working temperature: -40°C~+105°C
- No additional components required
- Stable performance and high reliability (MTBF≥3500K hours)
- Industry standard pin-out
- Flame-retardant case to meet UL94-V0 requirements
- SIP package

Selection Guide

Part No.	INPUT		OUTPUT			Full Load Efficiency (%/Typ)	Capacitive Load(μF)
	Normal (Vdc)	Range (Vdc)	Voltage (Vdc)	Min current (mA)	Max current (mA)		
WRA0505S-1WR2	5	4.5-9	±5	±5	±100	73	1000
WRA0512S-1WR2			±12	±2	±42	76	470
WRA0515S-1WR2			±15	±2	±33	75	330
WRB0503S-1WR2			3.3	30	303	71	1800
WRB0505S-1WR2			5	20	200	72	2200
WRB0512S-1WR2			12	9	87	76	1000
WRB0515S-1WR2			15	7	67	75	680
WRB0524S-1WR2			24	4	43	73	470
WRA1205S-1WR2	12	9-18	±5	±5	±100	77	1000
WRA1212S-1WR2			±12	±2	±42	81	470
WRA1215S-1WR2			±15	±2	±33	78	330
WRB1203S-1WR2			3.3	30	303	75	2700
WRB1205S-1WR2			5	20	200	77	2200
WRB1209S-1WR2			9	6	111	79	1800
WRB1212S-1WR2			12	9	87	78	1000
WRB1215S-1WR2			15	7	67	80	680
WRB1224S-1WR2	24	4	43	76	470		
WRA2405S-1WR2	24	18-36	±5	±5	±100	79	1000
WRA2409S-1WR2			±9	±3	±56	79	680
WRA2412S-1WR2			±12	±2	±42	78	470
WRA2415S-1WR2			±15	±2	±33	78	330
WRB2403S-1WR2			3.3	30	303	75	2700
WRB2405S-1WR2			5	20	200	77	2200
WRB2412S-1WR2			12	9	87	78	1000
WRB2415S-1WR2			15	7	67	78	680
WRB2424S-1WR2	24	4	43	77	470		
WRA4805S-1WR2			±5	±5	±100	76	1000

WRA4812S-1WR2	48	36-72	±12	±2	±42	78	470
WRA4815S-1WR2			±15	±2	±33	80	330
WRB4803S-1WR2			3.3	30	303	75	2700
WRB4805S-1WR2			5	20	200	76	2200
WRB4812S-1WR2			12	9	87	80	1000
WRB4815S-1WR2			15	7	67	79	680

customized accepted ,pls contact sales for details

Input Specifications

Item	Min	Typ	Max	Test Conditions	
Input Current (full load / no-load)	-	489/12mA	502/18mA	12VDC nominal input series, nominal input voltage	3.3V output
	-	625/12mA	641/18mA		Others
	-	238/5mA	245/12mA	24VDC nominal voltage input series, nominal input	3.3V output
	-	305/5mA	313/12mA		5V output
	-	298/10mA	305/16mA		Others
Reflected Ripple Current	-	50mA	-		
Surge Voltage (1sec. max.)	-0.7VDC	-	25VDC	12VDC nominal input voltage	
	-0.7VDC	-	50VDC	24VDC nominal input voltage	
Start-up Voltage	-	-	9VDC	12VDC nominal input voltage	
	-	-	18VDC	24VDC nominal input voltage	
Input Under-voltage Protection	5.5VDC	6.5VDC	-	12VDC nominal input voltage	
	12VDC	15.5VDC	-	24VDC nominal input voltage	
Ctrl	NONE-				
	NONE				
Hot Plug	Unavailable				

Output Specifications

Item	Typ	Max	Test Conditions
Voltage Accuracy	±1%	±2%	5%-100% load
Line Regulation	±0.1%	±1%	Input voltage variation from low to high at full load
Load Regulation	±0.5%	±1.5%	5%-100% load
Ripple&Noise	50mVp-p	100mVp-p	20MHz bandwidth, 5%-100% load

General Specifications

Switching Frequency	300KHz(Typ)	100% full load, nominal input voltage
Short-Circuit Protection	Continuous, self-recovery	
Case Temperature Rise	15°C (Typ)	
Temperature Coefficient	0.03%/°C	100% full load
Pin Soldering Resistance Temperature	300°C	Soldering spot is 1.5mm away from case for 10 seconds
Isolation (Input-Output)	1.6KVDC	Input-output Electric Strength test for

		1 minute with a leakage current of 1mA max.
Insulation Resistance (Input-Output)	1000MΩ	Input-output resistance 500Vdc
Operating Temperature	-40~+105°C	
Storage Temperature	-55~+125°C	
Storage Humidity	<95%	Non-condensing
Cooling Method	Free air convection	
Case Material	Black plastic; flame-retardant and heat-resistant (UL94 V-0)	
Weight	4.6g (Typ)	

**Unless specified, otherwise all other parameters are tested under the following conditions: nominal input voltage, pure resistive load, 25°C room temperature environment.

Dimensions and Recommended Layout

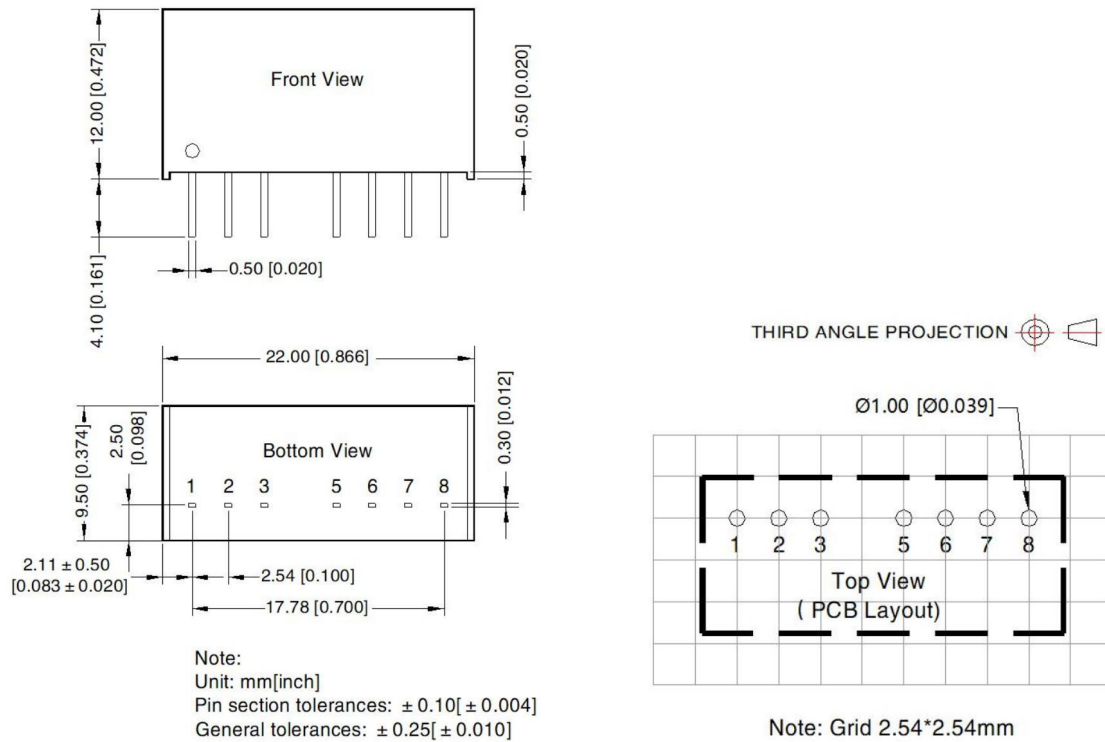

Pins

Pin	Single	Dual	
1	GND	GND	
2	Vin	Vin	
3	CTRL	CTRL	
5	NC	NC	
6	+Vo	+Vo	
7	0V	0V	

8	CS	-Vo	
---	----	-----	--

Recommended Circuit

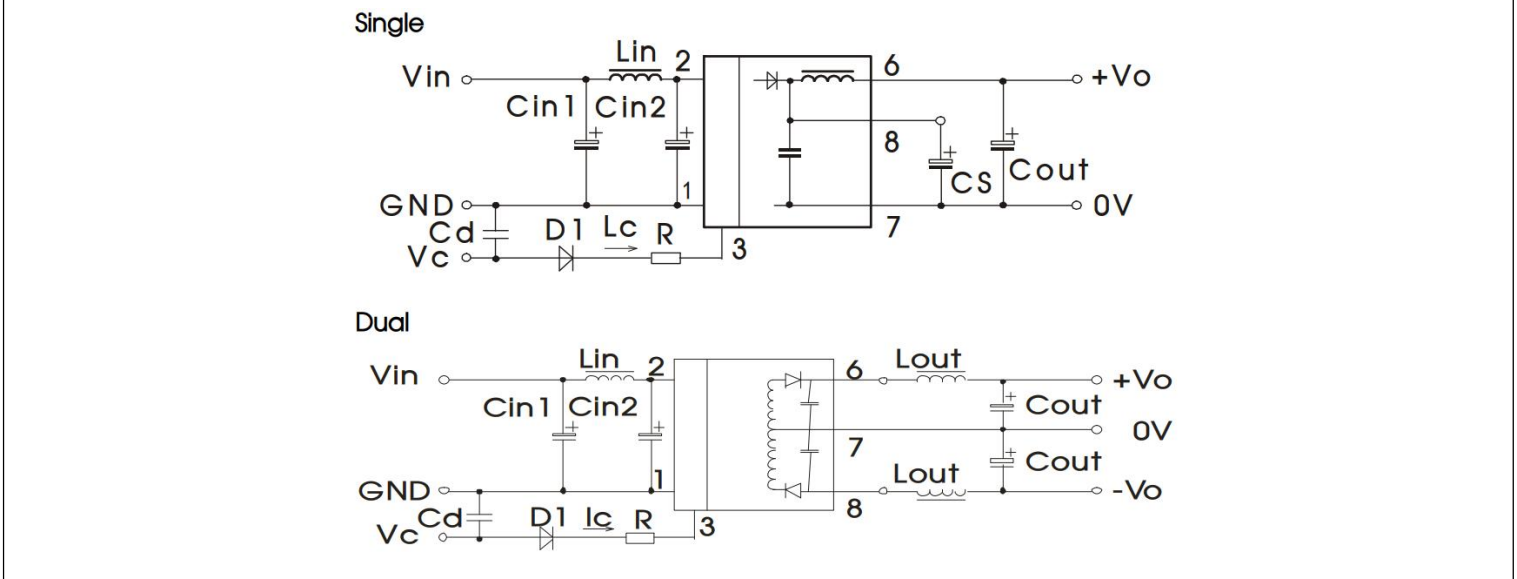

Recommended input and output capacitor values

	5VDC&12VDC	24VDC&48VDC		
V_{in}	5VDC&12VDC	24VDC&48VDC		
C_{in1}	100uF/25V	100uF/100V		
C_{in2}	47uF/25V	1uF/100V		
L_{in}	4.7uH-12uH			
C_s	10uF-22uF/50V			
C_{out}	$V_o(3/\pm 3/5/\pm 5/9/\pm 9)$:100uF/16V			
	$V_o(12/\pm 12/15/\pm 15)$:100uF/25V			
	$V_o(12/\pm 12/15/\pm 15)$:100uF/25V			
L_{out}	2.2uH-10uH			
C_d	4.7nF/100V			

Noted

1. Input current: Ensure that the output current of the power supply meets the instantaneous starting current of the power module (that is, twice the average input current of the power module).
2. Output load requirements: Avoid no-load use. When the actual power consumption of the load is less than 10% of the rated output power of the module or no load occurs, connect an external resistance to the output end (the sum of the external resistance and the load power is greater than or equal to 10% of the rated load) or select a module with a smaller rated power.
3. The external capacitance of the output end should not be too large; otherwise, the module may be overcurrent or poorly started. For details, see the external capacitance recommendation table.
4. External LC filter circuit can be connected for occasions with high ripple noise requirements.