

FEATURES:

- Wide input range
- Continuous short-circuit protection, self recover
- I/O isolation voltage 1.5KV
- Working temperature: -40°C~+85°C
- No additional components required
- Stable performance and high reliability (MTBF≥1000K hours)
- Industry standard pin-out
- Metal case
- DIP package



Selection Guide

Part No.	INPUT		OUTPUT				CapacitiveLoad(μF)
	Normal (Vdc)	Range (Vdc)	Voltage (V1dc)	current (mA)	Voltage (V2dc)	current (mA)	
LD150-24S05	12	9-18	5	30000			
LD150-24S12			12	125000			
LD150-24S15			15	10000			
LD150-24S18			18	8333			
LD150-24S24			24	6250			
LD150-24S28			28	5357			
LD150-24S48			48	3125			
LD150-48S05	24	18-36	5	30000			
LD150-48S12			12	125000			
LD150-48S15			15	10000			
LD150-48S18			18	8333			
LD150-48S24			24	6250			
LD150-48S28			28	5357			
LD150-48S48			48	3125			
LD150-110S05	48	36-72	5	30000			
LD150-110S12			12	125000			
LD150-110S15			15	10000			
LD150-110S18			18	8333			
LD150-110S24			24	6250			
LD150-110S28			28	5357			
LD150-110S48			48	3125			

customized accepted ,pls contact sales for details

Input Specifications

Input Voltage	Input Voltage Range (Vdc)	Nom(Vdc)	Max (Vdc)
	9-18	12	18
	18-36	24	36
	36-72	48	72

	72-144	110	144
Hot Plug	Unavailable		
Output Specifications			
Item	Typ	Max	Test Conditions
Voltage Accuracy	±1%	±3%	0-100% load
Line Regulation	±0.2%	±0.5%	Input voltage variation from low to high at full load
Load Regulation	±0.5%	±1%	5%-100% load
Ripple&Noise	-	100mVp-p	20MHz bandwidth, 5%-100% load
Transient Recovery Time	300µs	500µs	25% load step change, Nominal input voltage
Over-voltage Protection	-	160%Vo	110%Vo(Min)
Over-current Protection	140%Io	190%Io	110%Io(Min)
Short-circuit Protection			Continuous, self-recovery
General Specifications			
Switching Frequency	300KHz(Typ)		PWM mode
MTBF	1000 K hours		MIL-HDBK-217F@25°C
Temperature Coefficient	0.03%/°C		100% full load
Isolation (Input-Output)	1.5KVDC		
Insulation Resistance	1000MΩ		Input-output resistance 500Vdc
Operating Temperature	-40~+85°C		
Storage Temperature	-55~+125°C		
Storage Humidity	5-95%		Non-condensing
Cooling Method	Free air convection		
Case Material	Aluminum alloy		
Weight	200g (Typ)		
**Unless specified, otherwise all other parameters are tested under the following conditions: nominal input voltage, pure resistive load, 25°C room temperature environment.			
Dimensions and Recommended Layout			

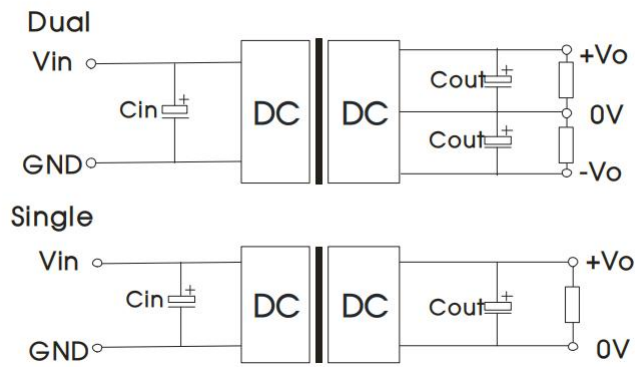

Recommended input and output capacitor values

Vin	Cin	Cout		
5	100uF/16V			
12	100uF/25V			
24	10uF/50V-47uF/50V			
48	10uF/100V-47uF/100V			

Noted

1. Input current: Ensure that the output current of the power supply meets the instantaneous starting current of the power module (that is, twice the average input current of the power module).
2. Output load requirements: Avoid no-load use. When the actual power consumption of the load is less than 10% of the rated output power of the module or no load occurs, connect an external resistance to the output end (the sum of the external resistance and the load power is greater than or equal to 10% of the rated load) or select a module with a smaller rated power.
3. The external capacitance of the output end should not be too large; otherwise, the module may be overcurrent or poorly started. For details, see the external capacitance recommendation table.
4. External LC filter circuit can be connected for occasions with high ripple noise requirements.