

FEATURES:

- Wide input range
- Continuous short-circuit protection, self recover
- I/O isolation voltage 3KV
- Working temperature: -40°C~+105°C
- No additional components required
- Stable performance and high reliability (MTBF≥3500K hours)
- Industry standard pin-out
- Flame-retardant case to meet UL94-V0 requirements
- SIP package

Selection Guide

Part No.	INPUT		OUTPUT		Full Load Efficiency (%/Typ)	Capacitive Load(μF)
	Normal (Vdc)	Range (Vdc)	Voltage (Vdc)	Max/Min current (mA)		
UWE1205S-1WR3	12	4.5-36	±5	±100	71	220
UWE1212S-1WR3			±12	±42	74	150
UWE1215S-1WR3			±15	±33	74	68
UWF1205S-1WR3			5	200	71	470
UWF1209S-1WR3			9	111	72	220
UWF1212S-1WR3			12	87	74	330
UWF1215S-1WR3			15	67	74	220

customized accepted ,pls contact sales for details

Input Specifications

Item	Min	Typ	Max	Test Conditions	
Input Current (full load / no-load)	-	489/12mA	502/18mA	12VDC nominal input series, nominal input voltage	3.3V output
	-	625/12mA	641/18mA		Others
	-	238/5mA	245/12mA	24VDC nominal voltage input series, nominal input	3.3V output
	-	305/5mA	313/12mA		5V output
	-	298/10mA	305/16mA		Others
Reflected Ripple Current	-	50mA	-		
Surge Voltage (1sec. max.)	-0.7VDC	-	25VDC	12VDC nominal input voltage	
	-0.7VDC	-	50VDC	24VDC nominal input voltage	
Start-up Voltage	-	-	9VDC	12VDC nominal input voltage	
	-	-	18VDC	24VDC nominal input voltage	
Input Under-voltage Protection	5.5VDC	6.5VDC	-	12VDC nominal input voltage	
	12VDC	15.5VDC	-	24VDC nominal input voltage	
Ctrl	NONE-				
	NONE				
Hot Plug	Unavailable				

Output Specifications

Item	Typ	Max	Test Conditions
Voltage Accuracy	±1%	±2%	5%-100% load
Line Regulation	±0.1%	±1%	Input voltage variation from low to high at full load
Load Regulation	±0.5%	±1.5%	5%-100% load
Ripple&Noise	50mVp-p	100mVp-p	20MHz bandwidth, 5%-100% load
General Specifications			
Switching Frequency	300KHz(Typ)		100% full load, nominal input voltage
Short-Circuit Protection	Continuous, self-recovery		
Case Temperature Rise	15°C (Typ)		
Temperature Coefficient	0.03%/°C		100% full load
Pin Soldering Resistance Temperature	300°C		Soldering spot is 1.5mm away from case for 10 seconds
Isolation (Input-Output)	3KVDC		Input-output Electric Strength test for 1 minute with a leakage current of 1mA max.
Insulation Resistance (Input-Output)	1000MΩ		Input-output resistance 500Vdc
Operating Temperature	-40~+105°C		
Storage Temperature	-55~+125°C		
Storage Humidity	<95%		Non-condensing
Cooling Method	Free air convection		
Case Material	Black plastic; flame-retardant and heat-resistant (UL94 V-0)		
Weight	4.6g (Typ)		

**Unless specified, otherwise all other parameters are tested under the following conditions: nominal input voltage, pure resistive load, 25°C room temperature environment.

Dimensions and Recommended Layout

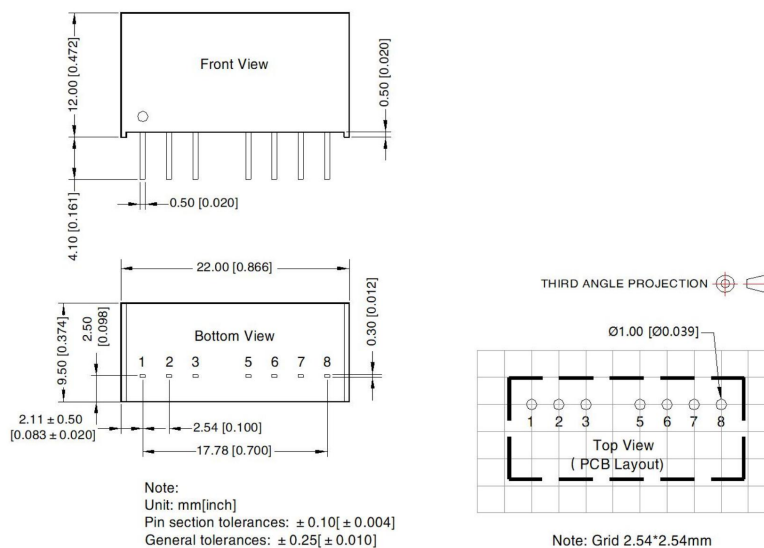

Pins

Pin	Single	Dual	
1	GND	GND	
2	Vin	Vin	
3	CTRL	CTRL	
5	NC	NC	
6	+Vo	+Vo	
7	0V	0V	
8	CS	-Vo	

Recommended Circuit

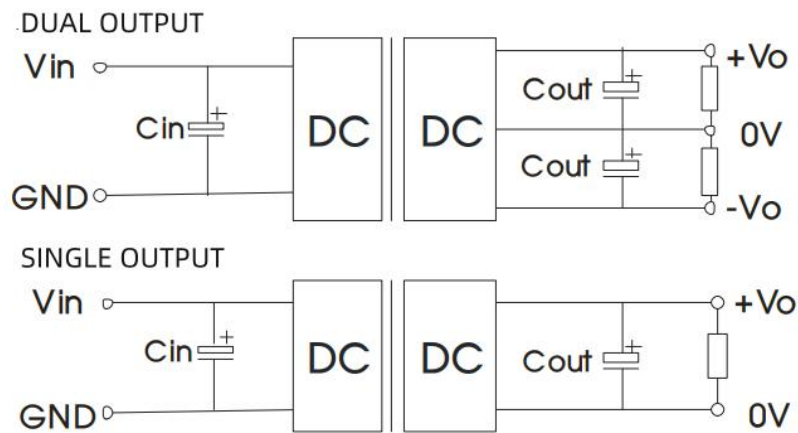

SINGLE Vout (VDC)	Cout (μF)	Cin (μF)	DUAL Vout (VDC)	Cout (μF)	Cin (μF)
5/9/12/15	22 (25V)	100 (50V)	±5/±12/±15	22 (25V)	100 (50V)

Noted

1. Input current: Ensure that the output current of the power supply meets the instantaneous starting current of the power module (that is, twice the average input current of the power module).
2. Output load requirements: Avoid no-load use. When the actual power consumption of the load is less than 10% of the rated output power of the module or no load occurs, connect an external resistance to the output end (the sum of the external resistance and the load power is greater than or equal to 10% of the rated load) or select a module with a smaller rated power.
3. The external capacitance of the output end should not be too large; otherwise, the module may be overcurrent or poorly started. For details, see the external capacitance recommendation table.
4. External LC filter circuit can be connected for occasions with high ripple noise requirements.