

FEATURES:

- Ultra wide voltage input,unregulated single/Dual output,3W
- Continuous short-circuit protection,self recover
- I/O isolation voltage 1.5KV/3KV
- Working temperature: -40°C~+105°C
- No additional components required
- Stable performance and high reliability (MTBF≥3500K hours)
- Industry standard pin-out
- Flame-retardant case to meet UL94-V0 requirements
- SMD package

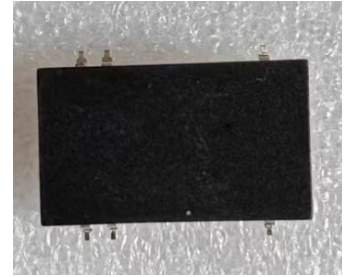

Selection Guide

Part No.	INPUT		OUTPUT			Full Load Efficiency (%/Typ)	I/O Isolation Voltage (KV)	Capacitive Load(μF)
	Normal (Vdc)	Range (Vdc)	Voltage (Vdc)	Min current (mA)	Max current (mA)			
BT3-24S3V3S3	24	9-36	3.3	60	600	74	3	1000
BT3-24S05S3			5	60	600	80	3	680
BT3-24S09S3			9	33	333	84	3	220
BT3-24S12S3			12	25	250	84	3	220
BT3-24S15S3			15	20	200	82	3	100
BT3-24D05S3			± 5	±30	±300	80	3	±470
BT3-24D09S3			± 9	±16	±167	84	3	±100
BT3-24D12S3			± 12	±13	±125	84	3	±20
BT3-24D15S3			± 15	±10	±100	83	3	±470
BT3-48S3V3S3			48	18-72	3.3	60	600	74
BT3-48S05S3	5	60			600	80	3	680
BT3-48S09S3	9	33			333	84	3	220
BT3-48S12S3	12	25			250	84	3	220
BT3-48S15S3	15	20			200	82	3	100
BT3-48D05S3	± 5	±30			±300	80	3	±470
BT3-48D09S3	± 9	±16			±167	84	3	±100
BT3-48D12S3	± 12	±13			±125	84	3	±20
BT3-12D15S3	± 15	±10			±100	83	3	±470

customized accepted,pls contact sales for details

Input Specifications

Input Filter	Capacitive Filter	
Ctrl	NONE	
	NONE	
Hot Plug	Unavailable	

Output Specifications

Item	Typ	Max	Test Conditions
Voltage Accuracy	±1%	±3%	input voltage range and load

Line Regulation	±0.2%	±0.5%	Input voltage from low to high voltage, full load
Load Regulation	±0.5%	±1%	10% to 100% full load
Ripple&Noise	50mVp-p	150mVp-p	20MHz Bandwidth, full load
General Specifications			
Switching Frequency	300KHz(Typ)		100% full load, nominal input voltage
Short-Circuit Protection	Continuous, self-recovery		
Case Temperature Rise	15°C (Typ)		
Temperature Coefficient	0.03%/°C		100% full load
Pin Soldering Resistance Temperature	300°C		Soldering spot is 1.5mm away from case for 10 seconds
Isolation (Input-Output)	1.5KVDC、3KVDC		Input-output electric strength test for 1 minute with a leakage current
Insulation Resistance (Input-Output)	1000MΩ		Input-output resistance 500Vdc
Operating Temperature	-40~+105°C		
Storage Temperature	-55~+125°C		
Storage Humidity	<95%		Non-condensing
Cooling Method	Free air convection		
Case Material	Black plastic; flame-retardant and heat-resistant (UL94 V-0)		
Weight	1.3g (Typ)		

**Unless specified, otherwise all other parameters are tested under the following conditions: nominal input voltage, pure resistive load, 25°C room temperature environment.

Dimensions and Recommended Layout

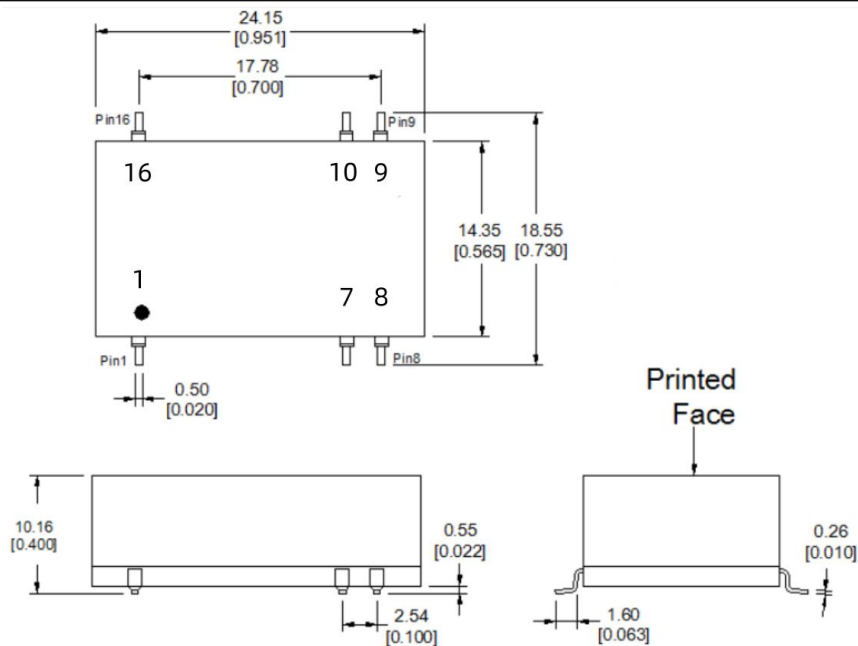

Unit:mm(inch)
Tolerance:±05(0.02)

Pins			
Pin	SINGLE	DUAL	
1	GND	GND	
7	NC	NC	
8	NC	0V	
9	+Vo	+Vo	
10	0V	-Vo	
16	Vin	Vin	

Recommended Circuit

SINGLE



DUAL

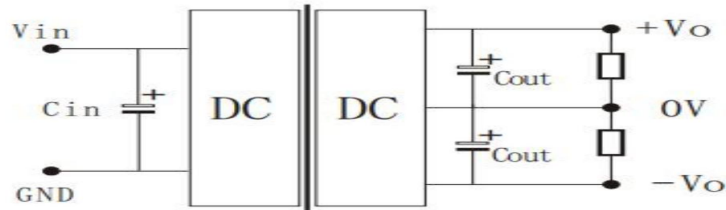

Vout	Cout	Cin
3.3VDC/5VDC	100uF	22uF
12VDC/15VDC	47uF	
24VDC	10uF	
±3.3VDC/5VDC	±47uF	
±12VDC/15VDC	±22uF	
±24VDC	±4.7uF	

Noted

1. Input current: Ensure that the output current of the power supply meets the instantaneous starting current of the power module (that is, twice the average input current of the power module).

2. Output load requirements: Avoid no-load use. When the actual power consumption of the load is less than 10% of the rated output power of the module or no load occurs, connect an external resistance to the output end (the sum of the external resistance and the load power is greater than or equal to 10% of the rated load) or select a module with a smaller rated power.
3. The external capacitance of the output end should not be too large; otherwise, the module may be overcurrent or poorly started. For details, see the external capacitance recommendation table.
4. External LC filter circuit can be connected for occasions with high ripple noise requirements.