

**FEATURES:**

- Wide voltage input range, broadband noise filtering; Low ripple output
- Typical efficiency 82%
- High isolation voltage, short circuit, overload, overheat protection self-recovery
- Miniaturized design
- Fast dynamic response
- Size:301\*241\*94mm
- Weight:4.5KG
- Widely used in military,communications,industrial control,transportation, electric power,new energy and scientific research and experiment and other fields



**Selection Guide**

Part No.	INPUT		OUTPUT				CapacitiveLoad(μF)
	Normal (VAC)	Range (VAC)	Voltage (V1dc)	current (A)	Voltage (V2 dc)	current (A)	
LAF3000E-220S24	220	175-265	24	125			
LAF3000E-220S28			28	107			
LAF3000E-220S48			48	62.5			
LAF3000E-220S110			110	27.3			

\*\*customized accepted,pls contact sales for details\*\*

**Input Specifications**

Input Voltage Range	Input Voltage Range (Vac)	Nom(Vac)	Max (Vac)
	165-265	220	265

**Output Specifications**

Item	Min	Typ	Max	Test Conditions
Voltage Accuracy		±1%		
Voltage Adjust Rate		±0.2%		
Load Regulation		±0.5%		
Auxiliary Voltage Accuracy		±3%		
Ripple&Noisy		±1%		
Temperature Regulation		±0.02%/°C		
Over Current Protect	120%		150%	
Short Circuit Protect	Burp type, self-recovery			
Dynamic Response	400μS		25% load	

**General Specifications**

Isolation Resistor	200MΩ	Input-Output
Isolation Voltage	1500VAC	Input-Output
	1000VAC	Input-Case
	500VDC	Output-Case
Switching Frequency	300KHz	Mil HDBK 217F Tc=25°C
MTBF	200000Hrs	

Case Temperature	-40~+100℃	
Storage Temperature	-55~+125℃	
Relative Humidity	5%-90%	
Pin Solder Temperature	250℃	Soldering spot is 1.5mm away from case for 10 seconds
Hand Soldering Time	5s	Iron Temperature 425 ℃
Temperature Coefficient	±0.02%/℃	
Shock	5G	10~55Hz
Cooling	Free Air	
Weight	4.5KG (Typ)	

\*\*Unless specified, otherwise all other parameters are tested under the following conditions: nominal input voltage, pure resistive load, 25℃ room temperature environment.

**Dimensions and Recommended Layout**

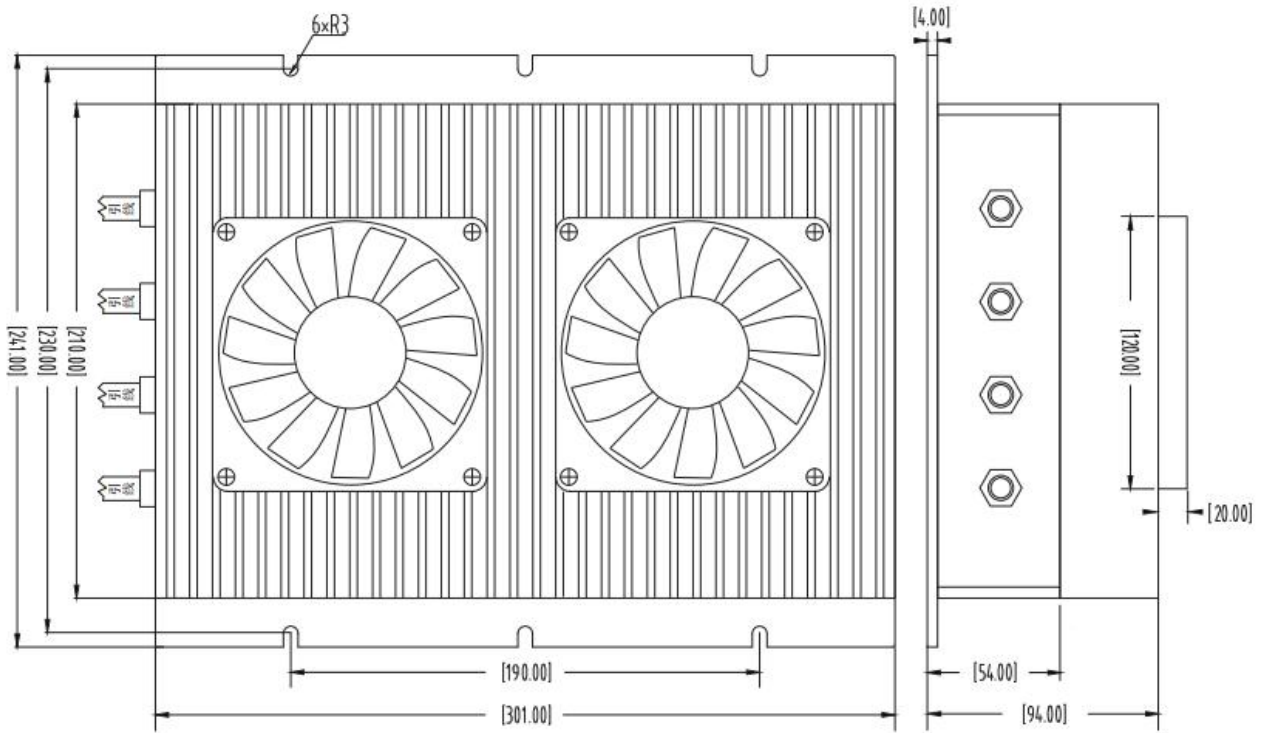

Unit:mm

**Recommended Circuit**

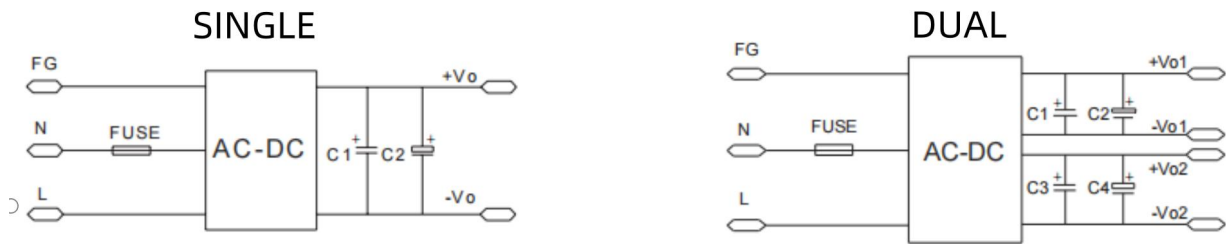

**Remark:**

Output filter capacitors C1 and C3 to remove high-frequency noise, it is recommended to use 1 $\mu$ F ceramic capacitor, capacitor voltage drop greater than 80%; The output filter capacitors C2 and C4 are electrolytic capacitors. It is recommended to use high-frequency and low-resistance electrolytic capacitors with a capacity of 100 $\mu$ F/1A output current, and the capacitance voltage drop is greater than 80%. FUSE: Mandatory, 3.15A/250V recommended, slow break.

**Noted**

1. Input current: Ensure that the output current of the power supply meets the instantaneous starting current of the power module (that is, twice the average input current of the power module).
2. Output load requirements: Avoid no-load use. When the actual power consumption of the load is less than 10% of the rated output power of the module or no load occurs, connect an external resistance to the output end (the sum of the external resistance and the load power is greater than or equal to 10% of the rated load) or select a module with a smaller rated power.
3. The external capacitance of the output end should not be too large; otherwise, the module may be overcurrent or poorly started. For details, see the external capacitance recommendation table.
4. External LC filter circuit can be connected for occasions with high ripple noise requirements.